

# PHASE NOISE IN MIMO SYSTEM: BAYESIAN CRAMER RAO LOWER BOUNDS IN SOFT INPUT ESTIMATION

R.MANVITHA<sup>1</sup>, G.CHAITHANYA RAVI<sup>2</sup> and R.LEKHYA<sup>3</sup>B.LAKSHMI PRASANNA<sup>4</sup>

1 R.MANVITHA B.tech manvithareddy74@gmail.com

2 G.CHAITHANYA RAVI B.tech lovelychaitu555@gmail.com

3 R.LEKHYA B.tech lekhyareddy444@gmail.com

4B.LAKSHMI PRASANNA B.tech prasu.mom@gmail.com

## ABSTRACT

This project addresses the estimation of time varying phase noise caused by imperfect oscillators in multiple input and multiple output (MIMO) systems. The estimation problem is parametrized in detail and based on an equivalent signal model is dimensionally reduced to minimize the overhead associated with phase noise estimation.

New exact and closed-form expressions for the Bayesian Cramer-Rao lower bounds (BCRLBs) and soft-input maximum a posteriori (MAP) estimators for online, i.e., filtering and offline, i.e., smoothing, estimation of phase noise over the length of a frame are derived. Simulations demonstrate that the proposed MAP estimators mean square error (MSE) performances are very close to the derived BCRLBs at moderate-to-high signal-to-noise-ratio. **Key Words:** MIMO, BCRLB, SNR MAP estimators

## 1. INTRODUCTION

There are four types of antenna technology

- They are SINGLE INPUT SINGLE OUTPUT (SISO), SINGLE INPUT MULTIPLE OUTPUT (SIMO), MULTIPLE INPUT SINGLE OUTPUT (MISO), MULTIPLE INPUT MULTIPLE OUTPUT (MIMO). SISO system, both the transmitter and the receiver have one antenna, and data transmission over the air is through a single radio frequency (RF) signal chain. An example of SISO type of wireless is Bluetooth. SIMO system. In simo

there is one antenna at the transmitter side and multiple antennas (each with an RF chain respectively) at the receiver side. MISO system is the other way round, with multiple antennas (each with an RF chain respectively) at the transmitter and a single antenna at the receiver. An example of MISO is LMRS (Land Mobile Radio Systems). MIMO system is commonly used in today's wireless technology, including 802.11n Wi-Fi, Wi-MAX, LTE, etc. Multiple antennas (and therefore multiple RF chains) are put at both the transmitter and the receiver. An example of MIMO is home network. Because of having multiple antennas at the transmitter and the receiver more information can be sent in a short period of time. Phase noise is caused by both phase and frequency instabilities in the radio frequency oscillators which are used in wireless transceivers. In signal processing phase noise is the frequency domain representation of rapid, short term, random fluctuations in the phase of a wave form caused by time domain instabilities. Phase noise severely deteriorates the performance of MIMO systems, because independent oscillators used at each transmitting and receiving antennas, result in multiple phase noise. Based on the measurement driven representation phase noise is the sum as a power law process we evaluate closed form expressions for the relevant oscillators. Correlated phase noise is caused. It occurs when RF chain share a common phase lock loop for the local oscillator signals.

- Uncorrelated phase noise is caused. Multiple phase lock loop (PLL) signals are used to generate local oscillator signals. Multiple antenna of mimo systems are not co-located. Biased Cramer-Rao Lower Bound (BCRLB) is used to derive the estimate of unknown

parameters in a linear model with an arbitrary known additive noise probability density function (PDF). The biased estimator obtained by optimization of BCRLB is not necessary satisfactory in a general case; therefore, additional considerations must be taken into account. If the Fisher information matrix (FIM) is singular, we use the method of singular value decomposition (SVD) to extract the parameter estimate of linear model. For example we show that in a linear model, parameter estimation based on single observation leads to the normalized least mean square (NLMS). Data aided for offline are smoothing estimation of KN phase noise processes in a frame of K received signals. The whole frame of K received signals y is assumed to be available at the receiver and used to estimate the corresponding KN phase noise values. The NDA-BCRLB assumes no knowledge of the transmitted symbols of K and can be derived by taking into account the a priori distribution of transmitted symbols. To evaluate the NDA-BCRLB the likelihood function is obtained by averaging over the a priori distribution of S. Online :- in online estimation of data aided bcrbl only past and current observations can be estimated. Offline :- here past ,current and future observations can be estimated

- OFDM(Orthogonal frequency-division multiplexing)
- OFDM is a technology used to compress large amount of data into small amount of bandwidth
- OFDM is a method of digital modulation in which a signal is split into several narrowband channels at different frequencies.
- OFDM is similar to conventional frequency-division multiplexing (FDM).
- The technology lends itself to digital television, and is being considered as a method of obtaining high-speed digital data transmission over conventional telephone lines.

TYPES OF ERRORS:

- Mean square error(MSE):-The mean square error (MSE) of an estimator measures the average of the square of the errors i.e. the difference between

estimator and what is estimated MSE is a risk function corresponding to the expected value of square error loss or quadratic loss

- **Inter carrier interference(ICI):-**ICI is an impairment well known to degrade performance of orthogonal frequency division multiplexing (OFDM) transmissions. It arises from carrier frequency offsets from the Doppler spread due to channel time variation and to a lesser extent, from sampling frequency offsets
- **Bit error rate(BER):-**BER is a number of bit errors per unit time the number of bit errors divided by the total number of transmitted bits during a study time interval. it's a unit less performance measure .its expressed in percentage

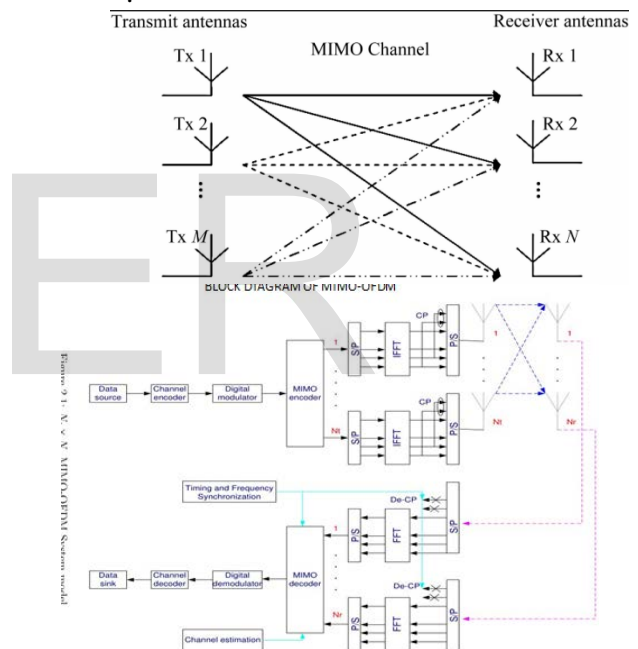

BLOCK DAIGRAM OF OFDM

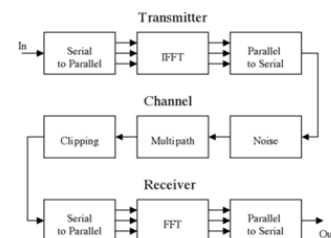

ALGORITHM FOR REMOVAL PHASE NOISE IN MIMO SYSTEMS BY USING BAYESIAN CRAMERRAO LOWER BOUNDS:

STEP1:-Initialise NT,NR, %2 \*2

SNR,channel(H),Lo\_vector,simulations.

- STEP2:-FIND THE PHASE NOISE INNOVATION FOR TRANSMITTER AND RECEIVER.
- STEP3:-FIND THE VARIANCE OF TRANSMITTER AND RECEIVER.
- STEP4:-SET THE VALUES FOR MATRIX I.  
DN11, DN12, DN21, DN22
- STEP5:- INITIALISE K=LENGTH  
[LO\_VEC],SIM,SUM,PIM.
- STEP6:-BY USING STIMULATIONS WE CALCULATE THETA(T),THETA(R) %THETA = MODIFIED PHASE NOISE
- STEP7:-BY USING THETA AND ZERO RANDOM VARIATIONS(W). WE CALCULATE % MULTI VARIATE GAUSSIAN RANDOM VARIABLE
- STEP 8:- CALCULATE QM,QMM,QN,QNN
- STEP 9:- BY USING PHI VALUES WE CALCULATE QMM,QNN
- STEP 10:- FINALLY WE GET THE PHASE NOISE INNOVATION IN TRANSMITTER AND RECEIVER
- LOOP:-  
FOR M=1:NT -1  
COMPUTE JD\_SIM(M , M)  
FOR N=1:NR  
COMPUTE JD\_SIM(N + NT -1,N+NT -1)  
END  
FINALLY WE CALCULATE JD\_SUM,JD
- STEP11:- INITIALISE JIN=0, DN11\_MOD % JIN+DN11
- STEP12:- SET K=LENGTH[LO\_VEC]

- STEP13:- IF K=1 OR ANY OTHER VALUE BY USING PREVIOUS MATRIX VALUES WE GET J\_DD
- STEP14:- INVERSE OF J\_DD GIVES THE ONLINE DD BOUND EVALUATION
- STEP15:- INITIALISE FIM,K=1:LO
- STEP16:- IF K=1 OR LO\_VEC WE USE INVERSE OF SIGMA TO CALCULATE PIM
- STEP17:- IF K= ANOTHER VALUE WE USE 2\*IN[SIGMA] TO CALCULATE PIM
- STEP18:-IF K=1:LO(-1) WE USE – INV[SIGMA] TO CALCULATE PIM
- STEP19:- BIM=FIM+PIM
- STEP20:- BCRB=INV (BIM).
- STEP21:- A DIAGONAL ELEMENTS OF MATRIX ARE REPLACED WITH BCRLB VALUES
- STEP22:- FINALLY WE PLOT SEMI LOG GRAPHS FOR

### GRAPH RESULT

